

The Pathway to Efficient Inorganic Artificial Leafs Using Advanced Photoelectrosynthetic Cells – Physicochemical Boundary Conditions and Material Science Challenges

Wolfram Jaegermann,
surface science lab, materials science, TU Darmstadt

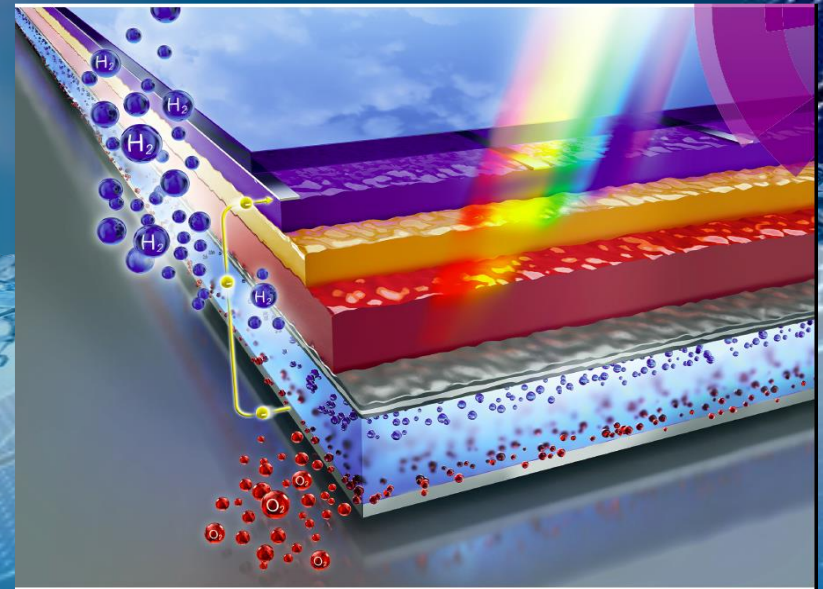

TECHNISCHE
UNIVERSITÄT
DARMSTADT

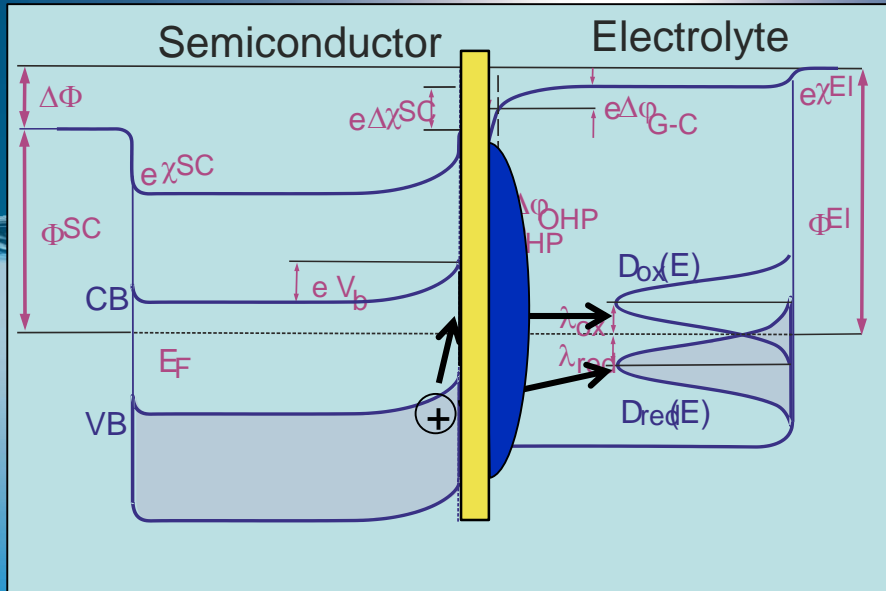

Routes to Solar H₂ by Artificial Leaves: Physical boundary conditions

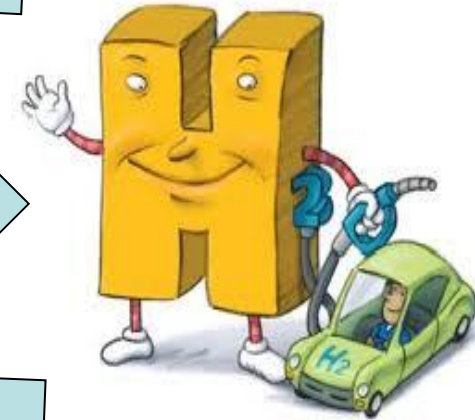
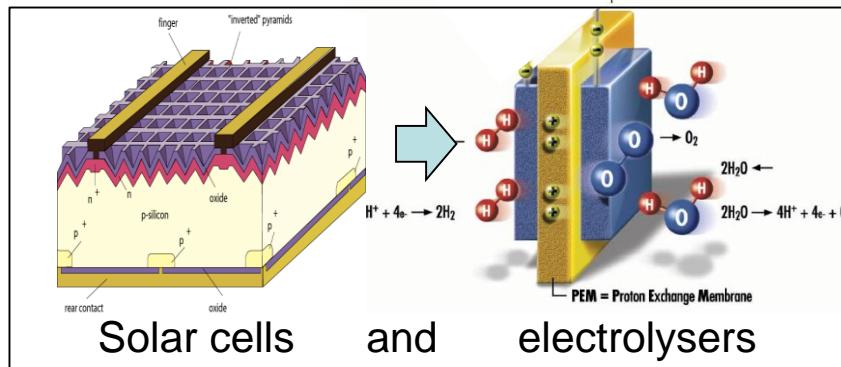
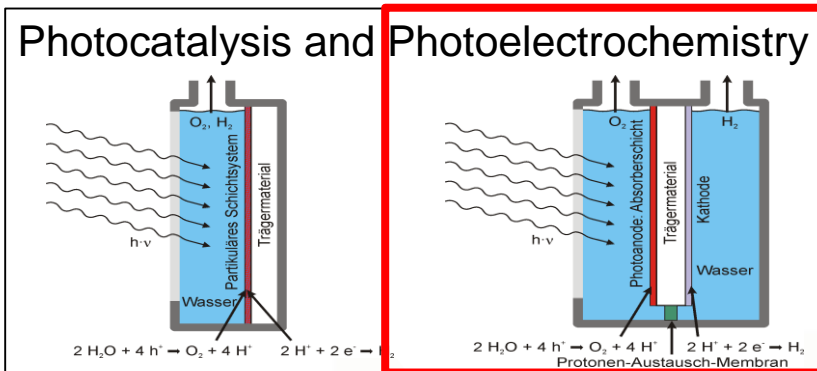
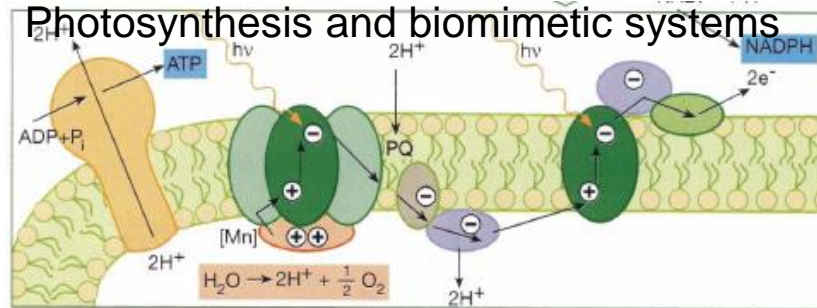

Routes to Solar H₂ by Artificial Leaves: Physical boundary conditions

Involved elementary processes are equivalent:

- Light absorption, charge carrier generation and separation
- Loss free interface transfer of chemical potential and photocurrent
- Minimisation of overpotentials of multielectron redox reactions

Optimisation needs of elementary steps are equivalent

but

Complexity of device structures,
given understanding,
and reached/expected performance
are not equivalent

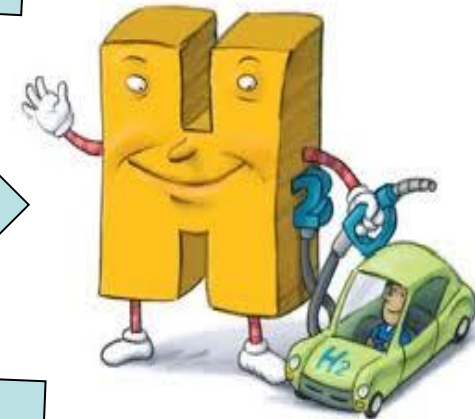

Photovoltaic converter requirements (Black box approach)

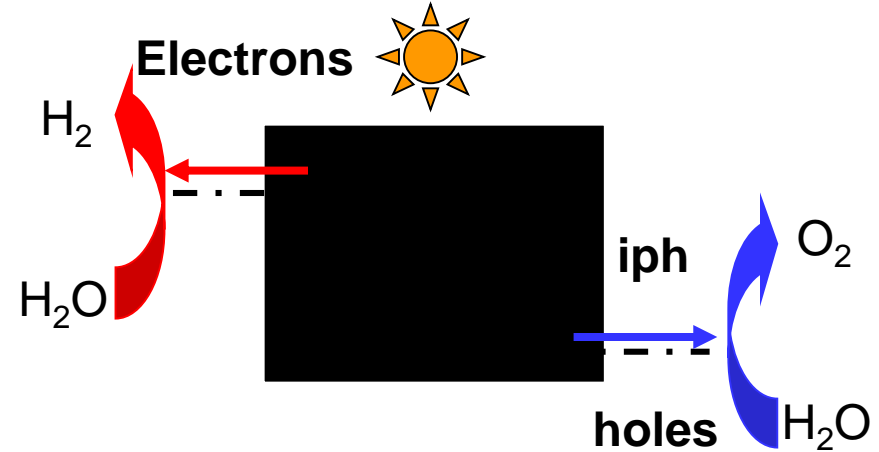
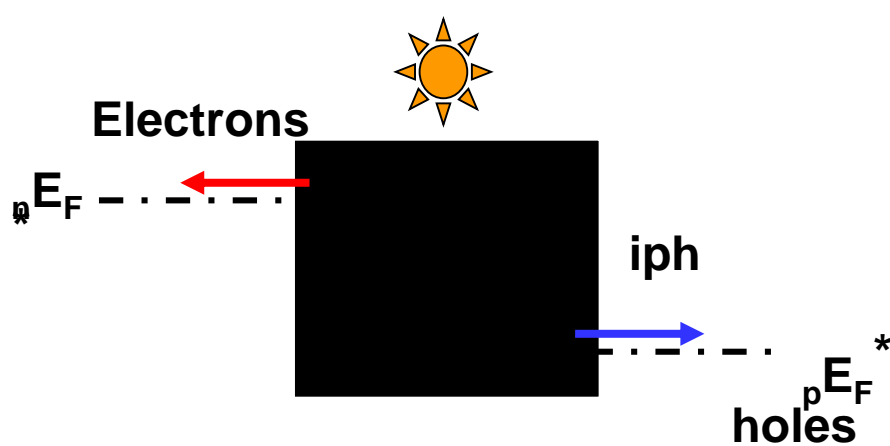

Optimisation of performance:

- Maximize photovoltage $U_{ph} <_n E_F^* - E_F^*$
- Maximize photocurrent i_{ph}

$$\eta^{el} = i_{ph} U_{ph} FF / P_{hv}$$

Optimisation of performance:

- Adjust photovoltage $U_{ph}^{op} > |E_{red} - E_{ox}|$
- Maximize photocurrent i_{ph}
- Minimize overvoltage losses η

$$\eta^{STH} = i_{ph} f \Delta E_{H_2O} / P_{hv} \quad (f=1 \text{ faraday eff.})$$

for operational $U_{ph}^{op} > \Delta E_{H_2O} + U_{loss}$

Performance to be considered for thin film Si multijunction PECs

Data from cooperation with Finger et al. FZ Jülich

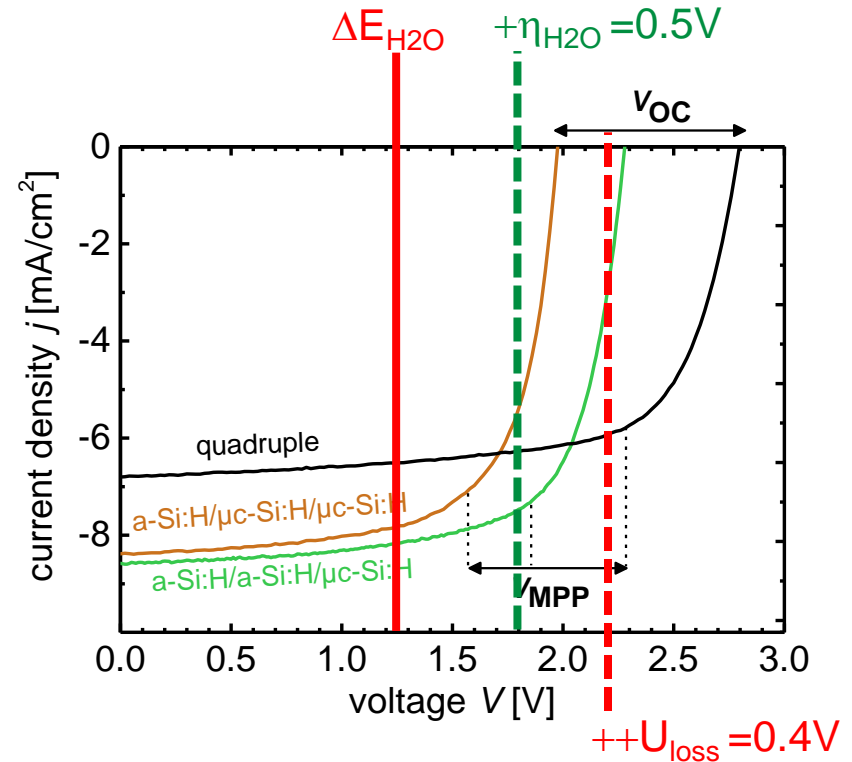
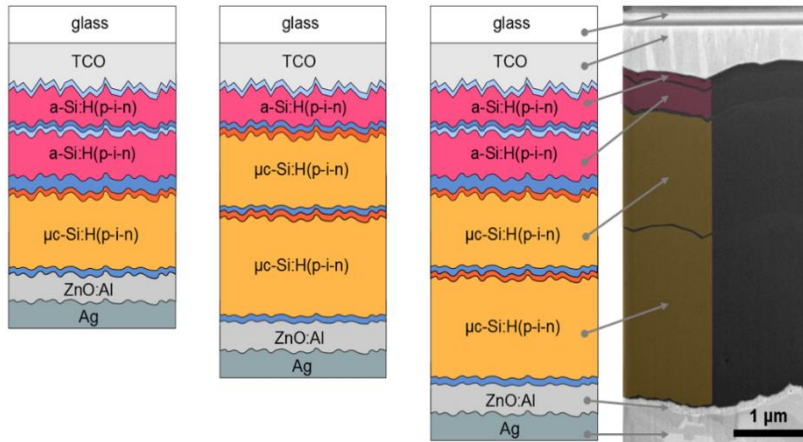

Driving force (U_{ph}^{op}) of PV component must exceed $1.6 V + U_{loss}$ at operation

$$\bullet U_{ph}^{op} > 1.23 V + 0.1 V + 0.3 V + 0.1 > 1.7 V + U_{loss}$$

ΔE_{H_2O} η_{HER} η_{OER} iR

1. step: Optimization of PV-Converter e. g. nip-Structures leading to high photocurrents

Optimisation: $j(U) = G(U) - R(U) \Rightarrow \eta_{\max} \leq 31\% \quad (AM\ 1,5)$

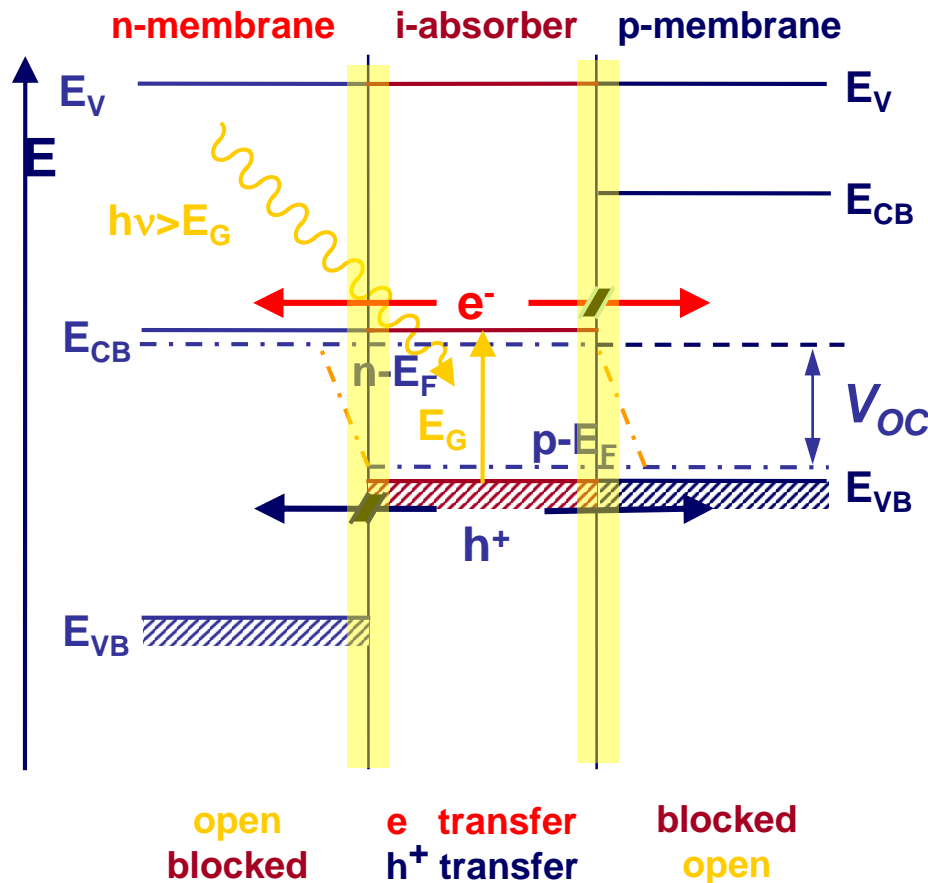

Illuminated: „ j_{ph} “ max



QE ($h\nu \rightarrow 1$)

$$L_{Diff} = (D \tau)^{1/2} > 3/\alpha$$

Illuminated: „ V_{OC} “ max



G max:

$$d > 3/\alpha \text{ and } L_{diff} > d$$



R min:

$$j_0 \propto \exp(-\Phi_B/kT)$$



$$R_{IF} = S_{IF} \Delta n q$$

$$S_{IF} = \sigma_{IF} v \text{ DOS}_{IF}$$

Single absorber PEC cell for water splitting

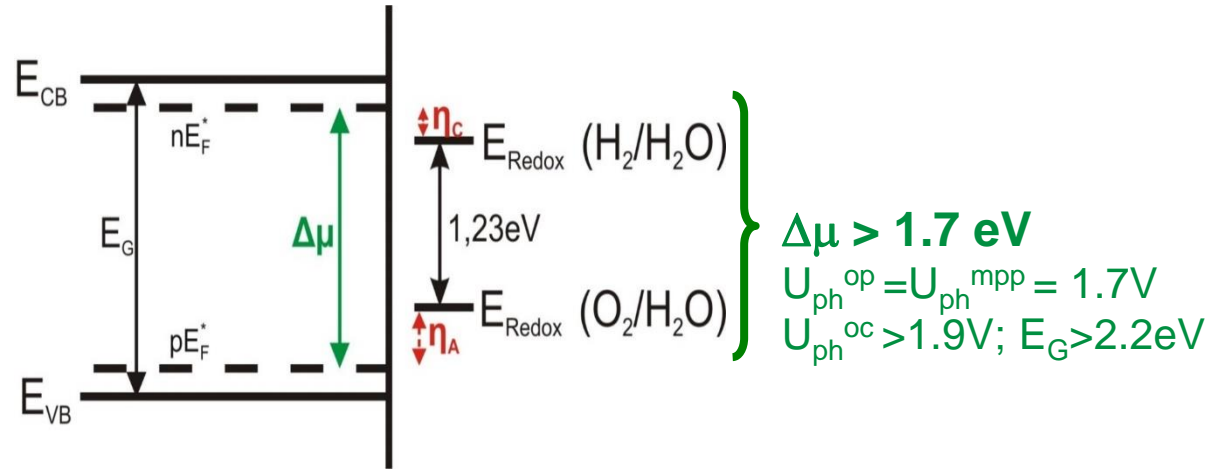
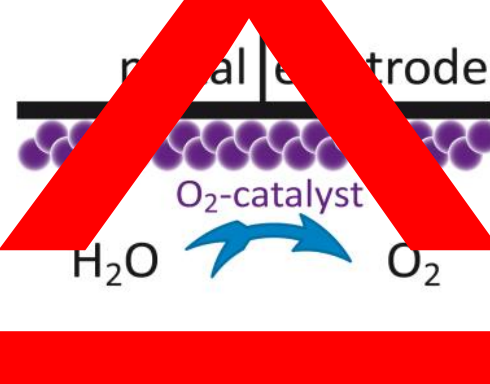
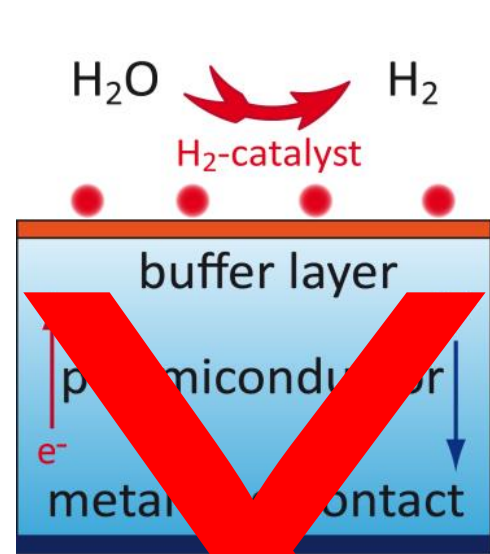

Fontaine, et al *Nature comm.* (2018)

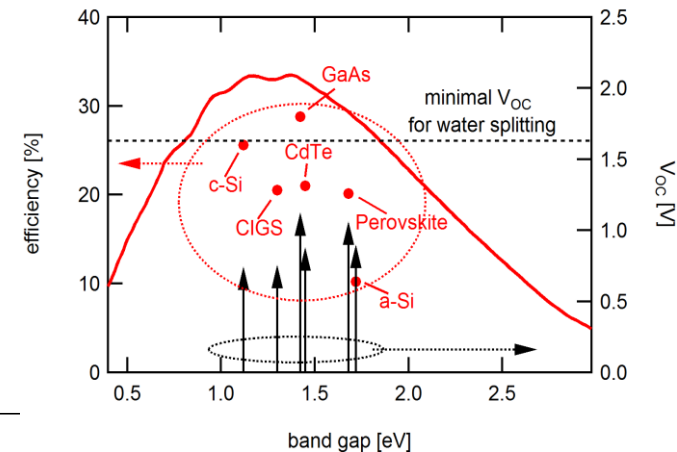
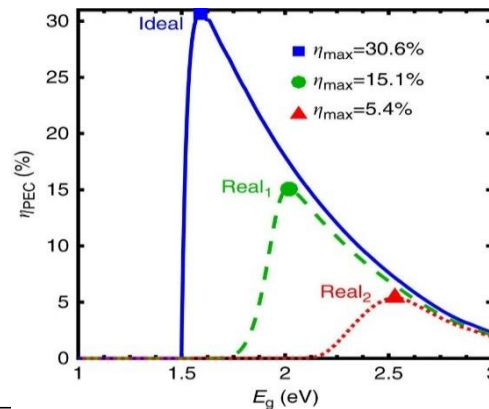

Tandem cell devices for PEC H₂O splitting cells

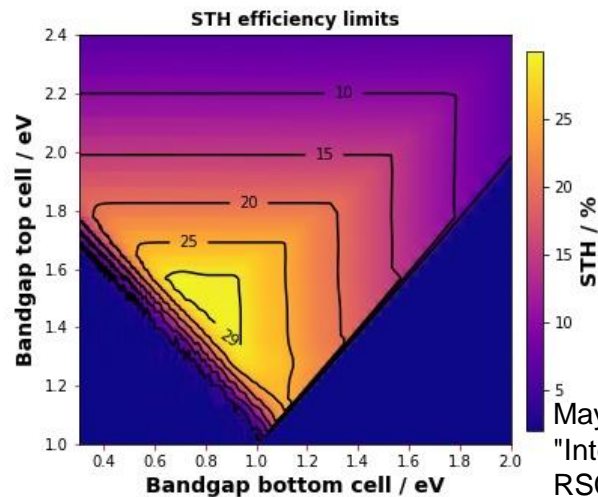
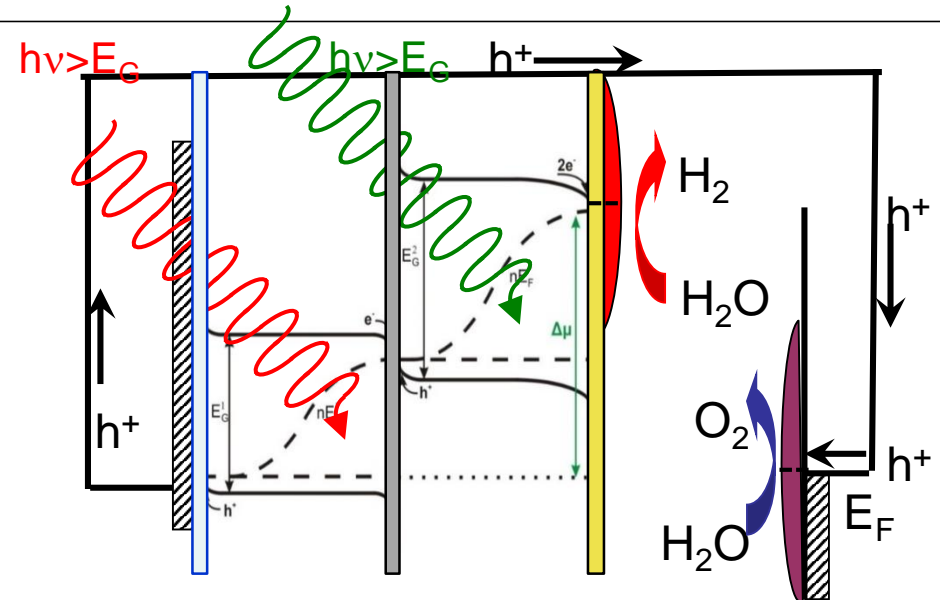
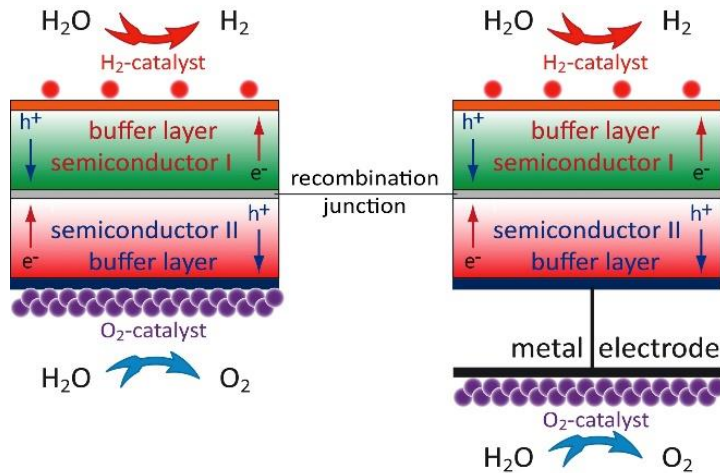

- Challenges:**
- Current coupling
 - Maximise photocurrent
 - Optimise Photovoltage
 - Stability
 - Cocatalysts
 - Superstrate arrangement

2. Step. Electrocatalysts for H₂O splitting reactions with minimized overpotentials

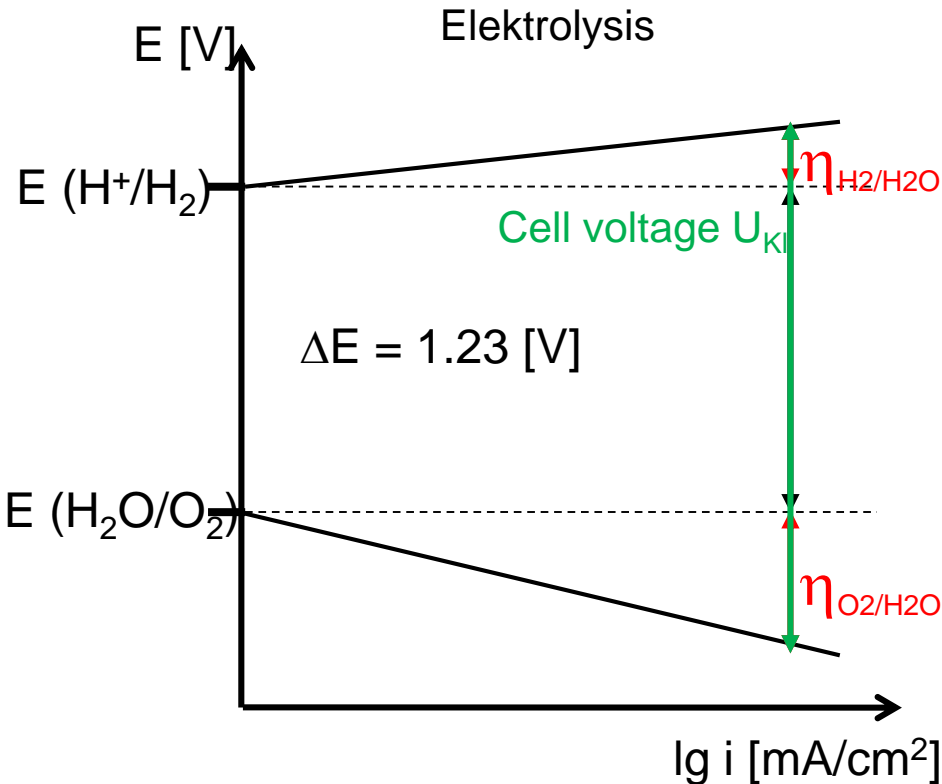

Energetic Stabilisation
of Intermediates e. g.

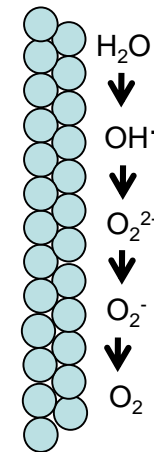

- which intermediates?
- which catalysts?
- which stabilisation?

$\Delta U = 1.23 \text{ V} + 0.1 \text{ V} + 0.3 \text{ V} + iR > 1.7 \text{ V}$

η_{H_2/H_2O} η_{O_2/H_2O}

- New catalysts: metals, oxides, biomimetic?
- Catalyst-support interaction?
- Catalyst nanostructure effects?
- Improved mechanistic understanding
- ...

Activity and availability of multielement catalysts

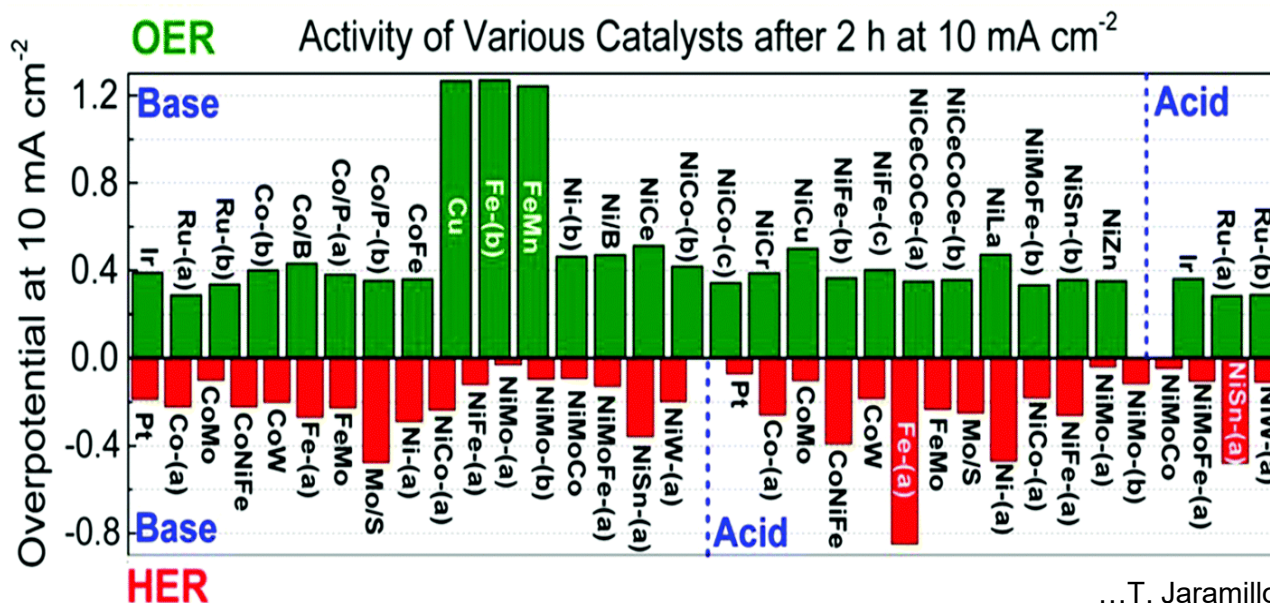

...T. Jaramillo, JACS 2015

- Fundamental understanding and optimization of benchmark catalysts
- Improved (uncritical) multielectron transfer catalyst with advanced properties
- Electronic coupling to PV absorber components and reducing interface losses

3. step: Addition of passivation layers and catalysts for water splitting

Optimisation: $j(U) = G(U) - R(U) \Rightarrow \eta_{\max} \leq 25(?)\% \quad (AM\ 1,5)$

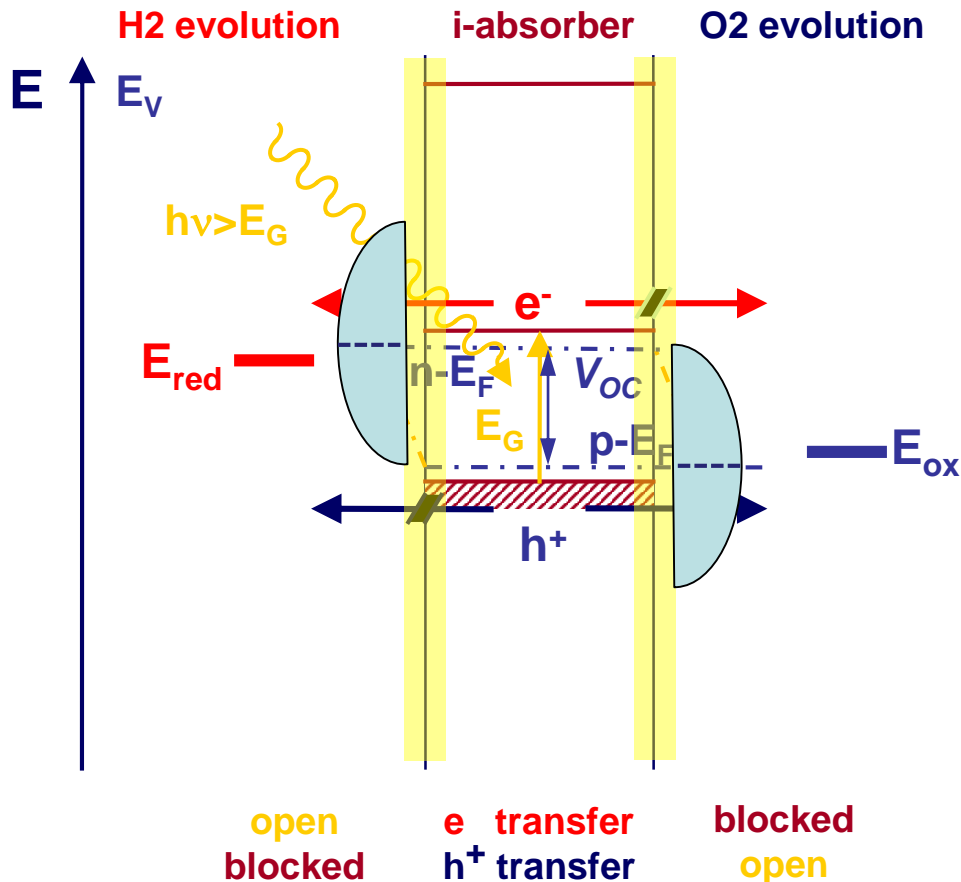

PEC Performance optimisation:

- interface engineering needed
- graded junctions
- buffer layers
- reaction layers
- catalysts

Chemically and structurally adjusted interfaces

Solid electrolyte interface engineering

Which elementary processes are involved in contact formation and charge transfer?

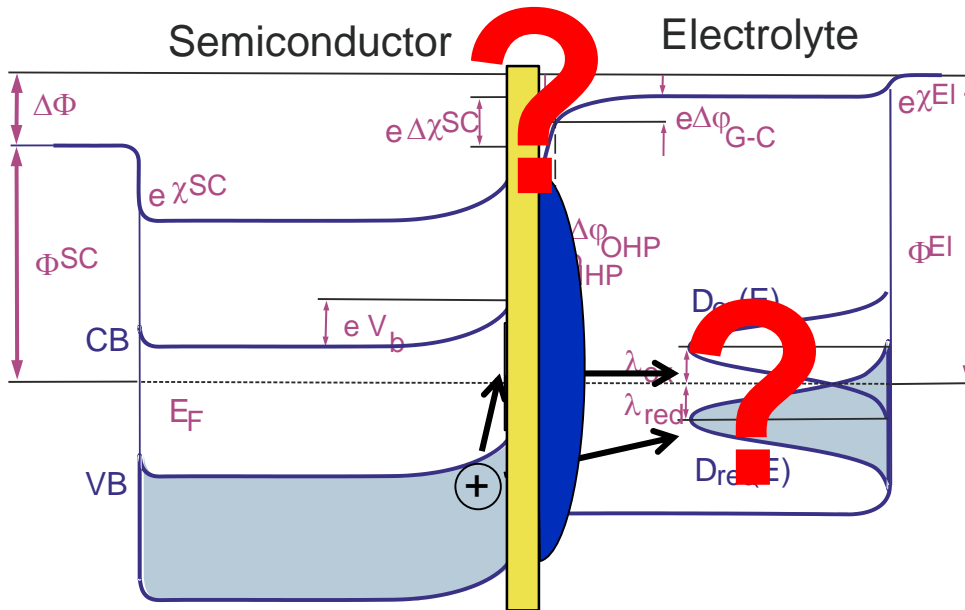

Marcus-Gerischer theory

$$W_{\text{ox}}(E) = \frac{1}{\sqrt{4\pi\lambda kT}} \text{Exp} \left(\frac{-(E - E_{\text{redox}}^0 + \lambda)^2}{4kT\lambda} \right)$$

$$W_{\text{red}}(E) = \frac{1}{\sqrt{4\pi\lambda kT}} \text{Exp} \left(\frac{-(E - E_{\text{redox}}^0 - \lambda)^2}{4kT\lambda} \right).$$

λ : reorganization energy

- ▶ Distribution of density of states across interfaces ?
- ▶ Marcus Gerischer theory only valid for reversible one-electron redox_couples
- ▶ Involvement of surface states, passivation layers and/or metal co-catalysts ?

Some achieved STH efficiencies for PECs: Immersed tandem (triple) cells

η_{STH}
12,4%

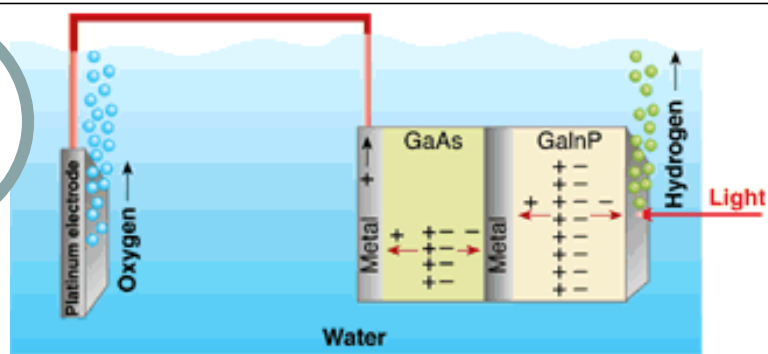

Khaselev.... Turner., **Science** (1998)

η_{STH}
19%

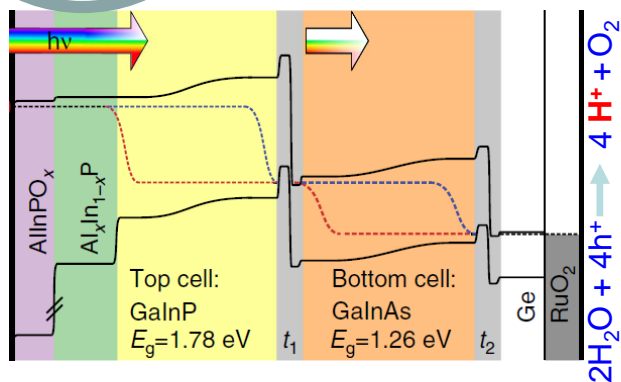

M. M. May, ..., T. Hannappel, **ACS energy letters** (2018)

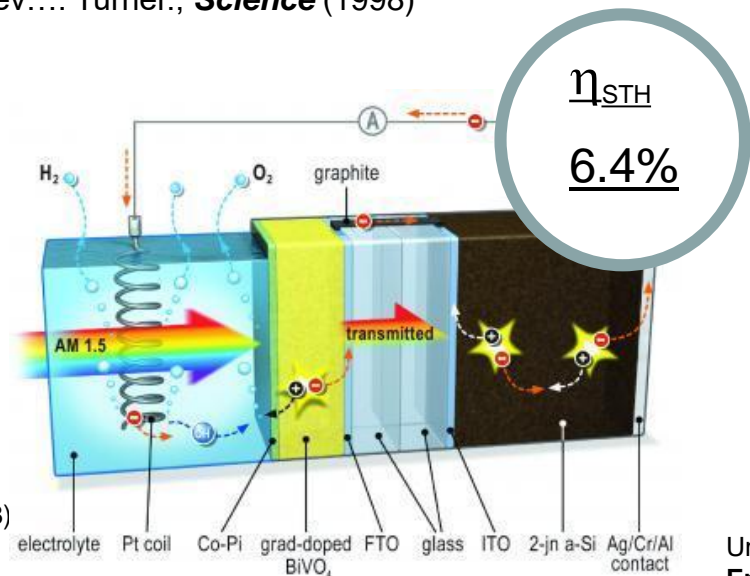

η_{STH}
6.4%

...Van de Krol, **Nature Communications** (2013)

η_{STH}
9.5%

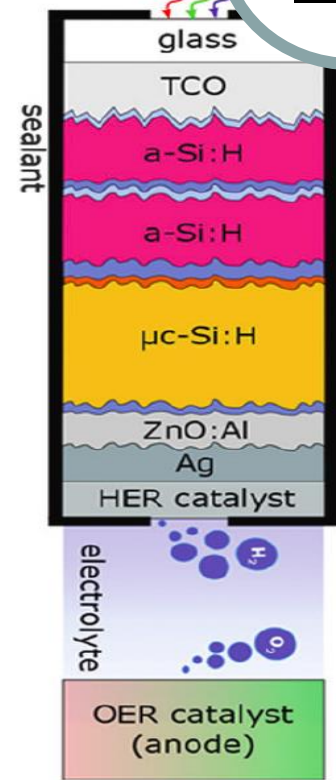

Urban ...Finger, ...Jaegermann, **Energy and Environmental science** (2016)

Device optimisation and engineering needs shown for buried junction tandem PEC-cell

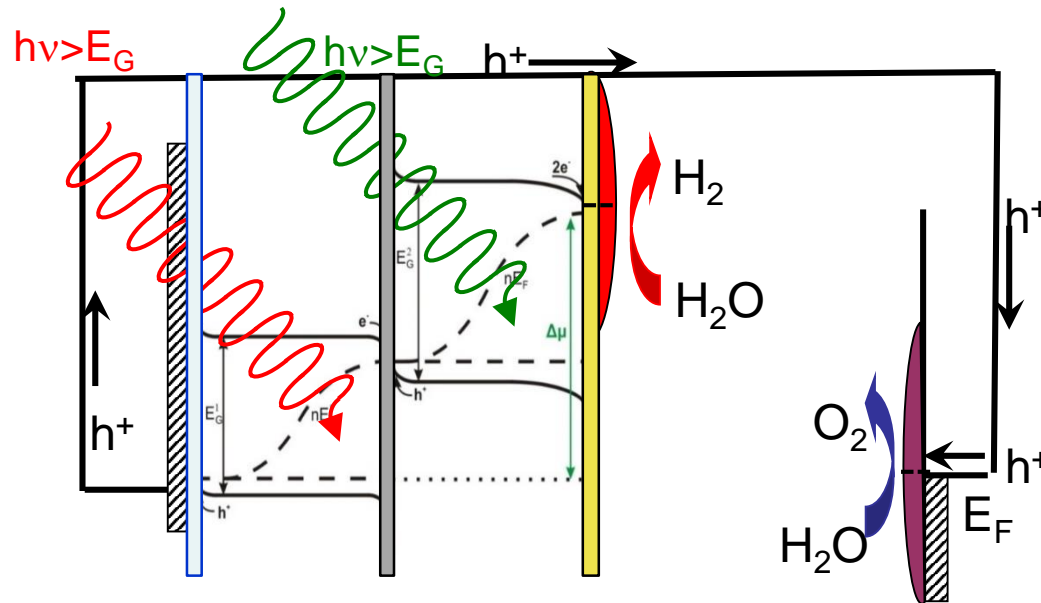

Individual component
engineering/
optimisation

1. PV engineering

2. Electrocat. engineering

3. Interface engineering

holistic device
engineering/
optimisation

Artificial leaves: Materials Science challenges for promising device structure (thin film tandems)

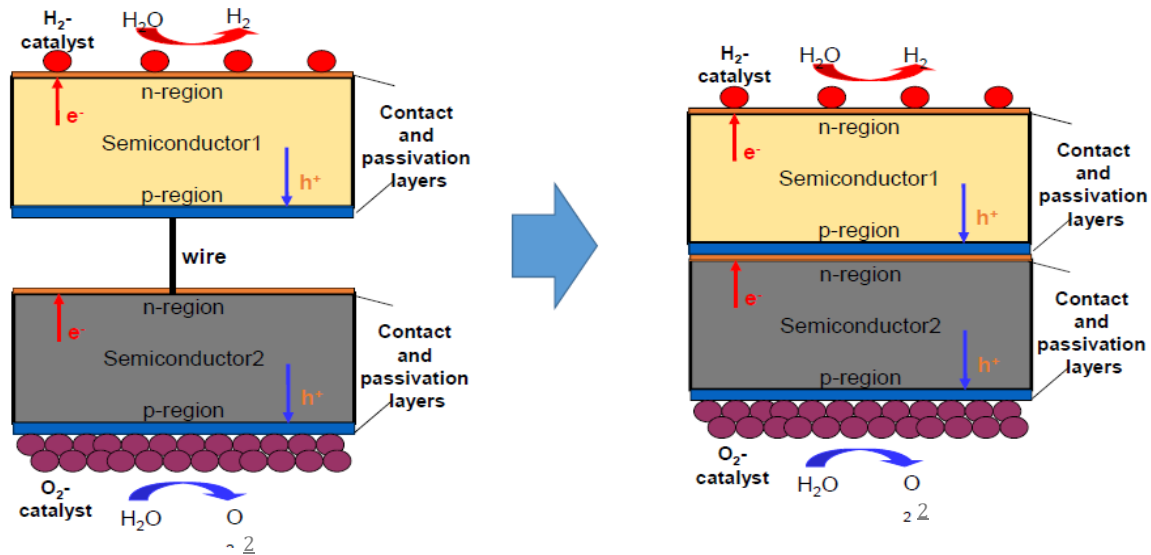

- Absorption of light: Two thin film absorber layers: EG1 about 1.2 eV, EG2 about 2 eV
- Interface engineering: Buried junctions with electronic and chemical passivation layers
- Adjusted multielectron transfer catalysts: Co-catalysts redox reactions needs to be adjusted to band edge positions
- Involved materials preferentially be based on non-critical materials

Generation 3 solar cells: Thin film tandem cells of inorganic thin films

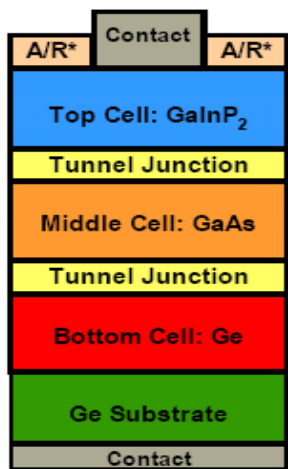

*A/R: Anti-Reflective Coating

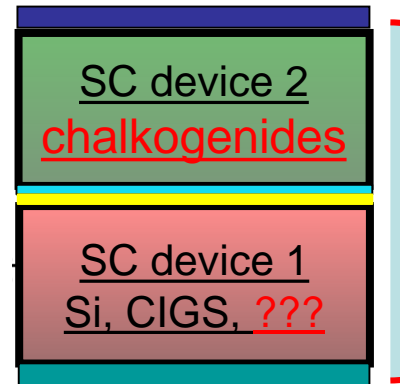
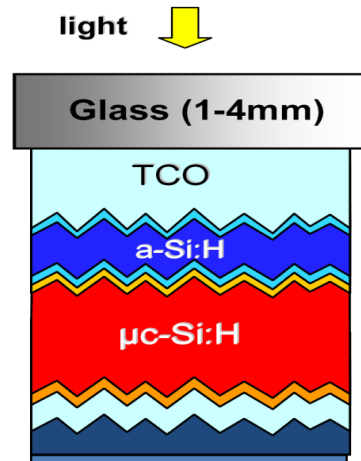

Novel
Materials

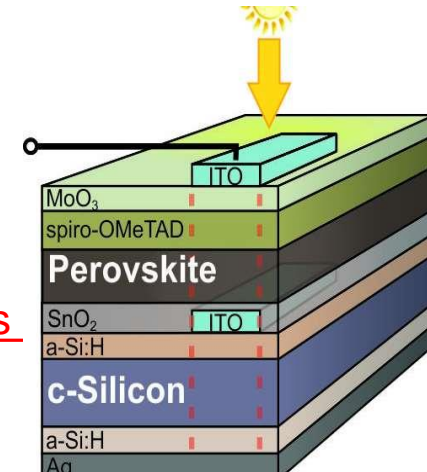

Expected advantages:

- Cheap deposition technology
- Low material consumption
- Cheap materials
- Economic **very** competitive
- Higher performance

Discussed disadvantages:

- Limited resources (?)
- hazardous materials (?)
- **nearly no scientific efforts yet**

Selection criteria of PV converters

(green: easily to be calculated by DFT)

- **Optical properties** (indirect gap vs direct gaps, forbidden transitions)
 - easily checked by optical measurements, DTF calculations
 - immediately rules out materials
- **Transport properties** (mobility, minority carrier lifetime, diffusion length)
 - intrinsic property effective mass given by DTF calculations
 - extrinsic properties. defects, recombination centers, given by materials manufacturing, related to **deposition technique** and substrate
- **Contact properties** (doping, homo-hetero interfaces, metal contacts)
 - can be checked by experimental studies, no proven and valid design strategies
 - immediately rules out materials
- **Morphology** (grain structure and texture, pinholes, secondary phases)
 - identified by SEM, XRD
 - may be solved by suitable **deposition technique** (huge parameter space)
 - strongly determined by interface thermodynamics, no kinetic control

Which materials to choose, are there clear criteria?
When is it worth to optimize a material or a device structure ?
How do we know where to start optimizing ?

Novel bandgap engineered oxide/chalkogenide Semiconductors: multinary compounds

Parent Oxides ? chalkogenides !

electronic structure based on filled d(s) states
e. g. $M d^0$, $M d^{10}$, $M s^2$, $M t_{2g}^6$

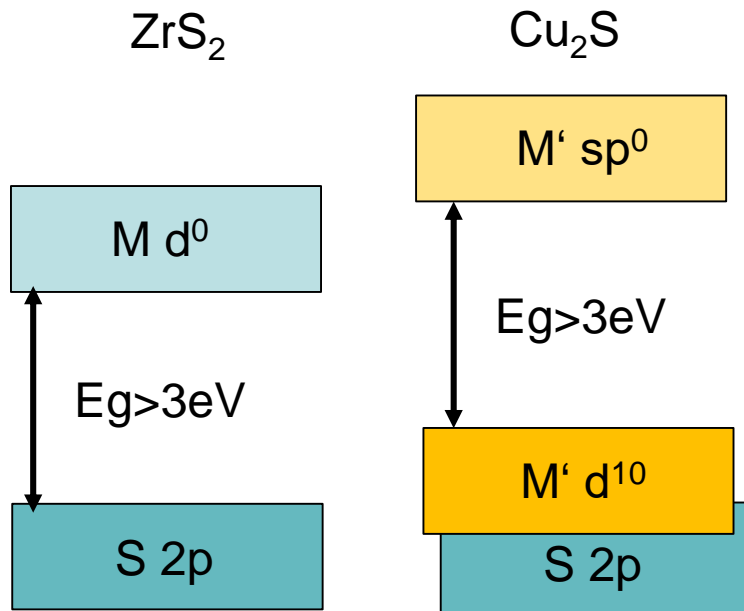

Novel Oxides ? chalkogenides !

Cu₂ZrS₃, etc

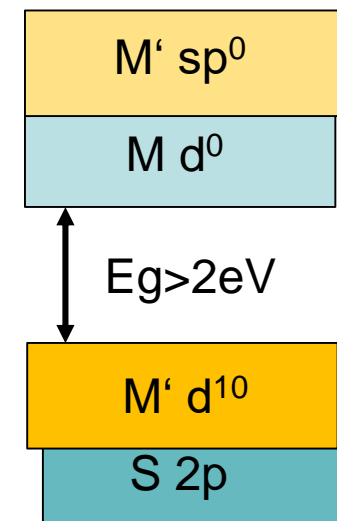

Bandgap Reduction with (?) retained favourable semiconductor properties: high absorption coefficients, high mobilities, high carrier lifetime ...

Detrimental effects due to localisation/redox reactions of semiconductor band edge states?

tendency to intra bandgap defect states:
polarons or reduction/oxidation states

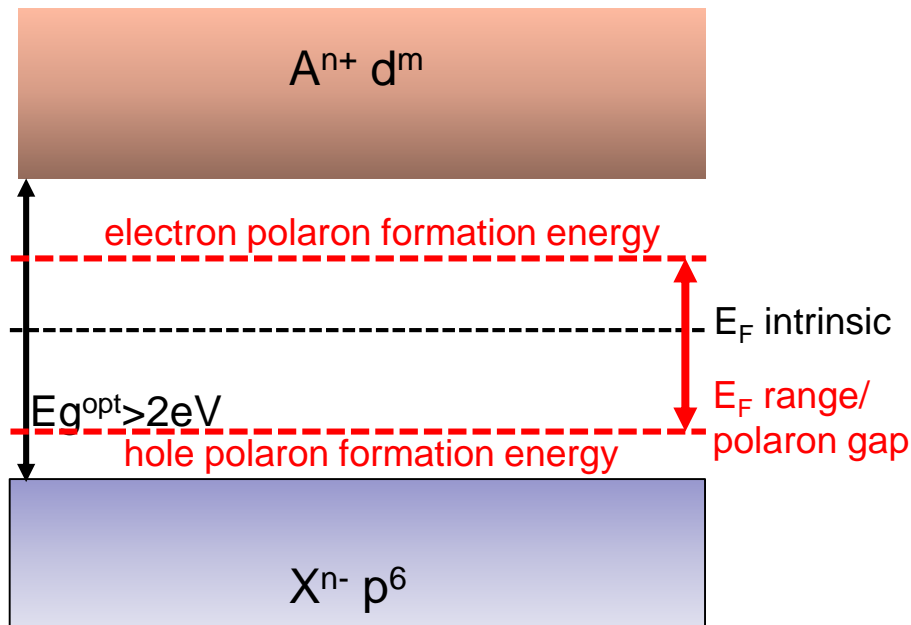

- optical gap \neq electronic gap
- polaron gap acts as effective bandgap reduce (quasi) Fermi level shifts!
- polarons reduce carrier mobility

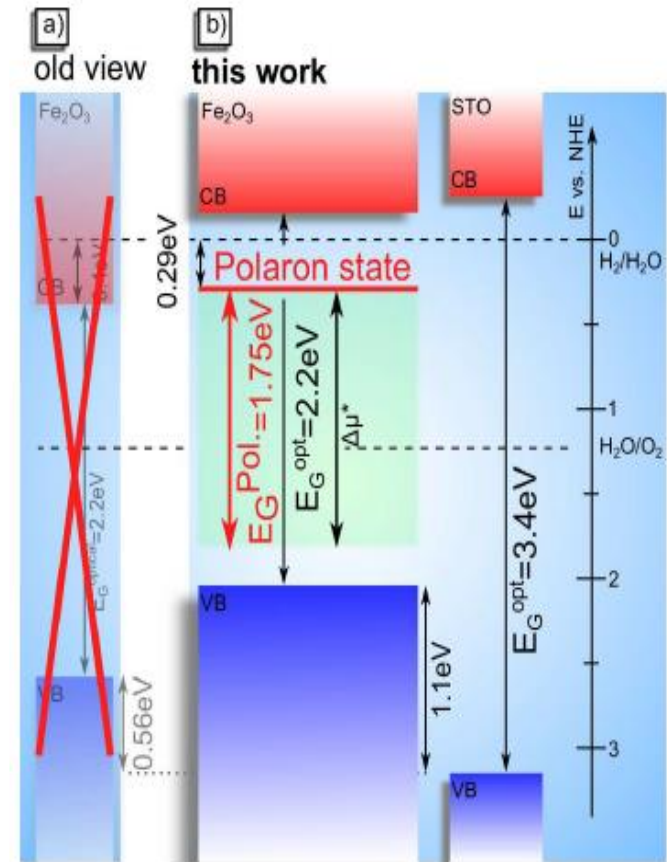

Lohaus, Klein, Jaegermann, Nature Commun. (2018)

Photoelectrolysis cell: interface and kinetic engineering needs

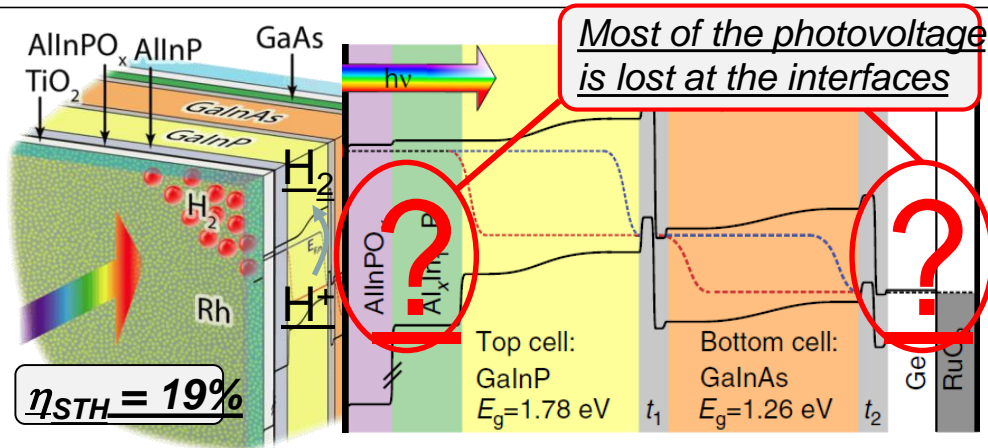

May, ..., Hannappel,
Nat. Commun. (2015);
ACS Energy Lett. (2018)

What may go wrong? Possible loss of U_{ph} and i_{ph}

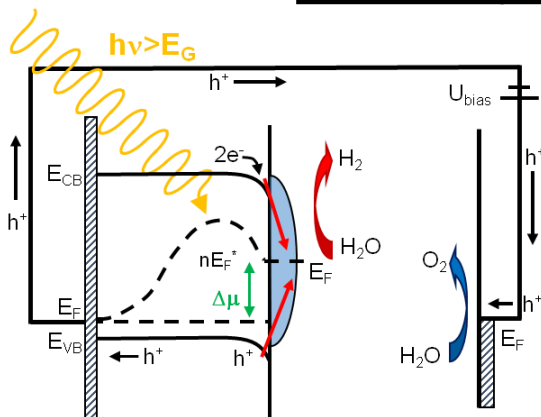

X Schottky contact:
Fermi level pinning

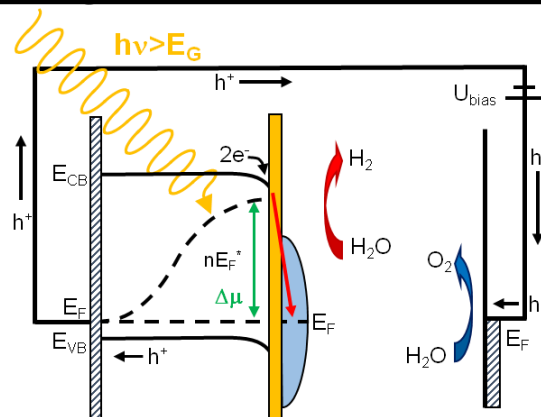

X Heterocontact:
Unfavorable adjustment

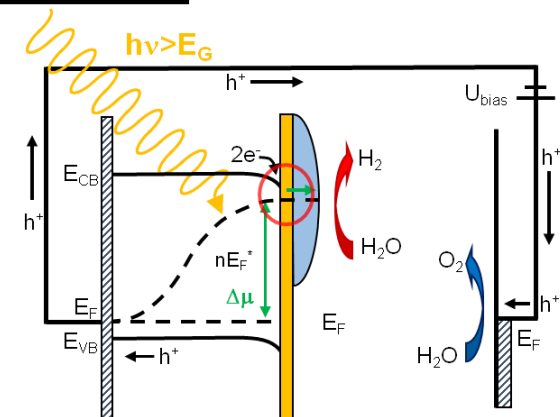

✓ SC buried junction:
Favorable adjustment

Photoelectrolysis cell: Interface engineering

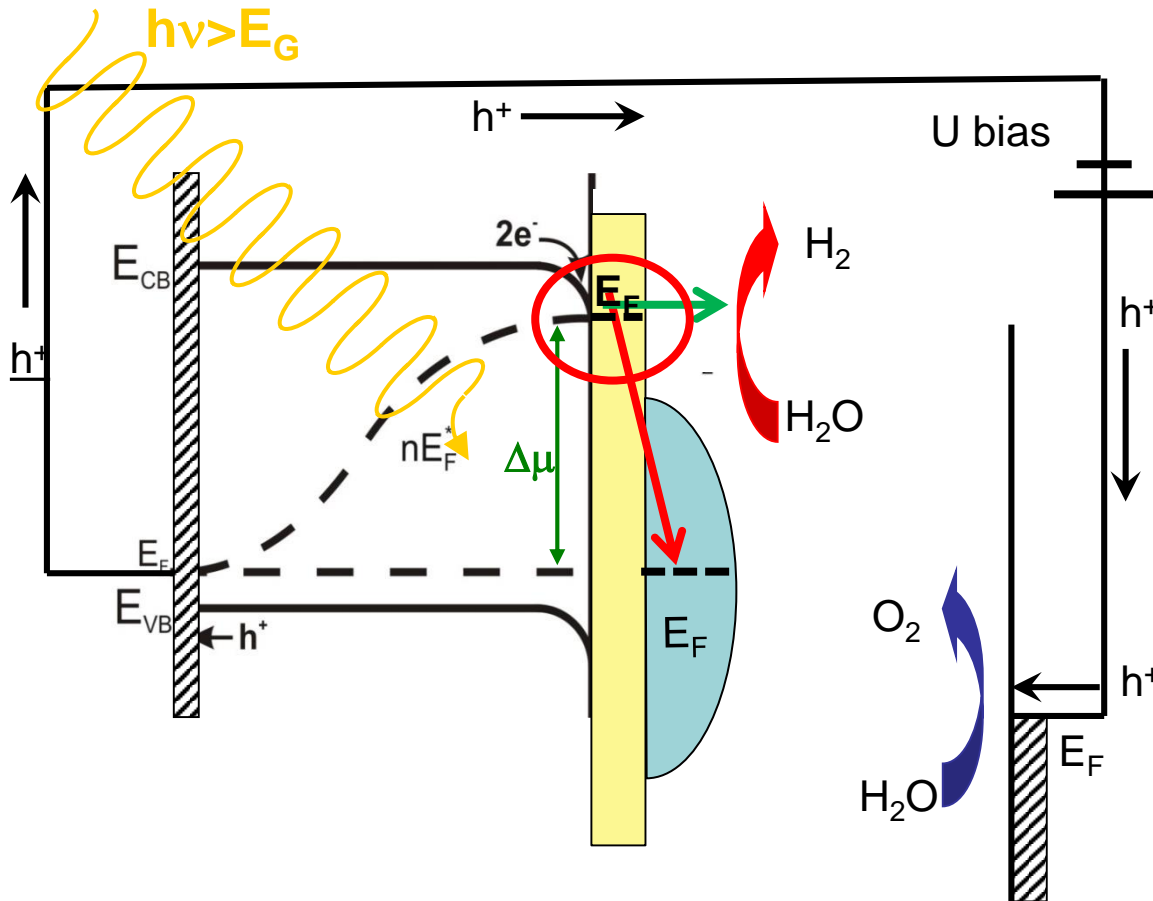

- **Interface engineering:**
 - chemical surface passivation
 - electronic surface passivation
 - energy line-up of quasi Fermi levels to redox electron states
- **Kinetic engineering:**
 - advanced catalysts (Pt, RuO_2 ...)
 - electronic coupling to SC substrate and electrolyte
 - No intermediate states with electron energies situated far from band edges allowed

Research needs: Adjusted energetic alignment of improved and uncritical electrocatalysts

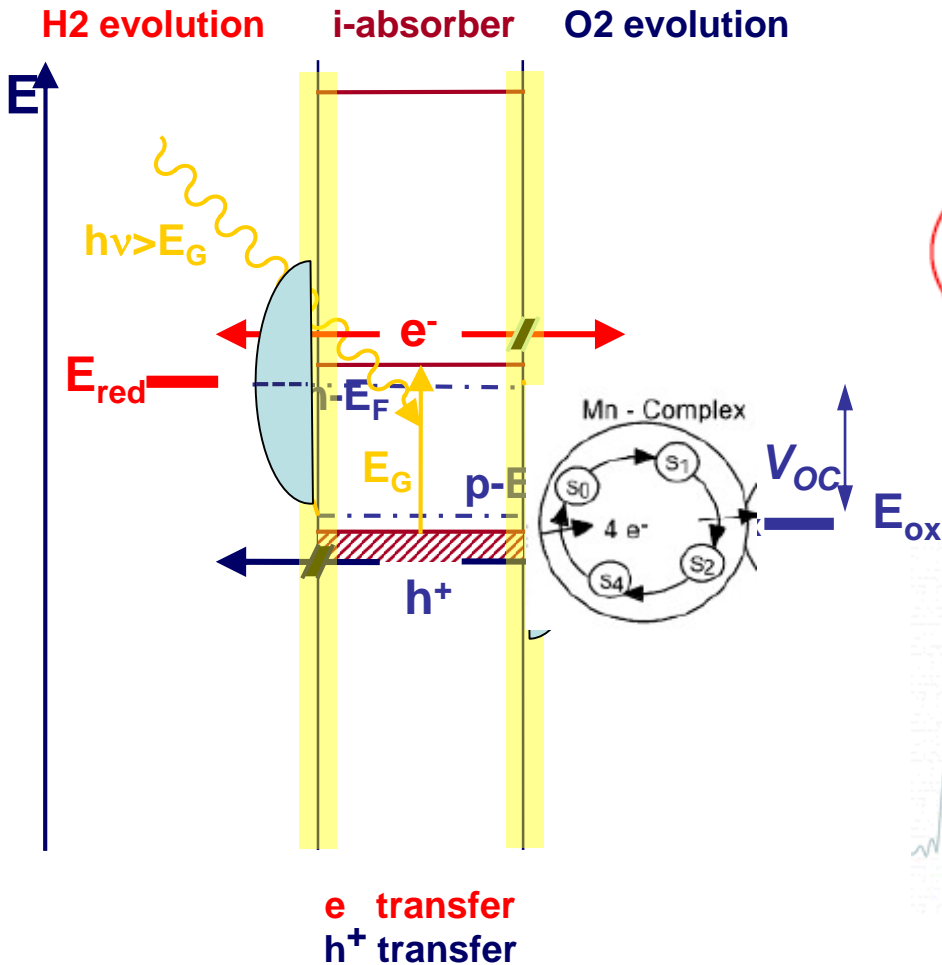

Specifically designed electrocatalysts

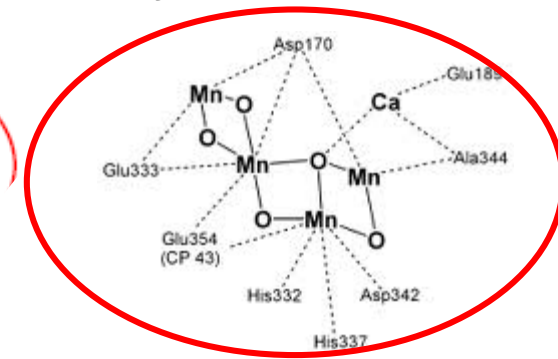
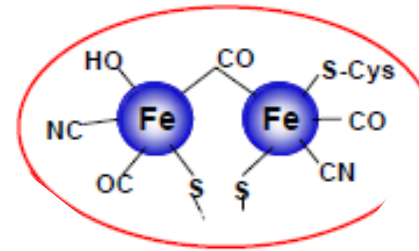

biomimetic Hammerström et al

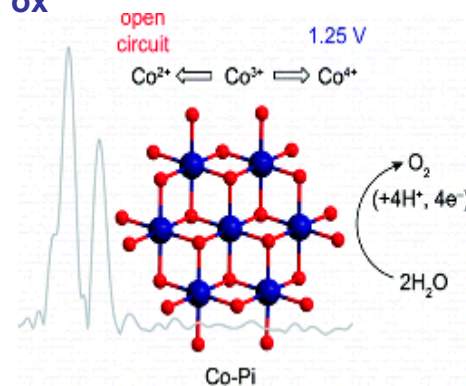

Nocera et al

Metal oxides

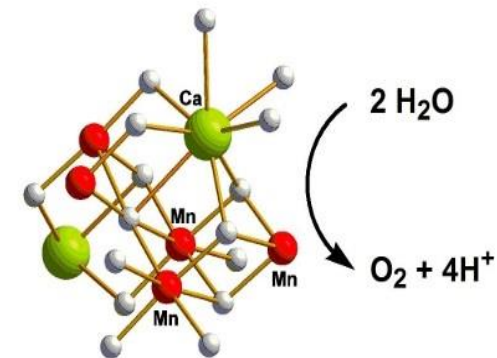

Kurz et al

Co-catalyst engineering: surface electronic structure and inner interfacial double layer potential drops



TECHNISCHE
UNIVERSITÄT
DARMSTADT

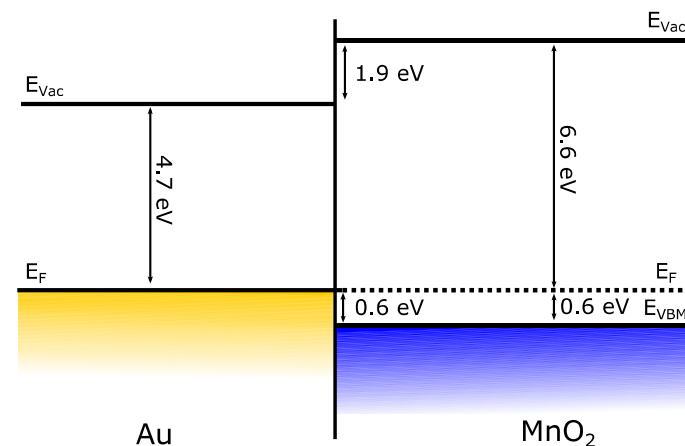
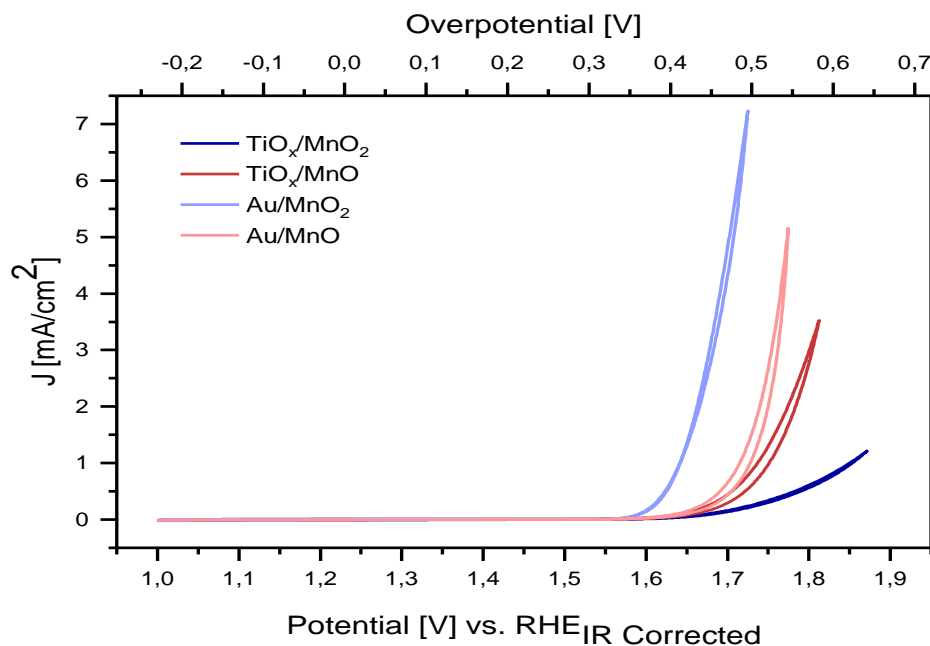
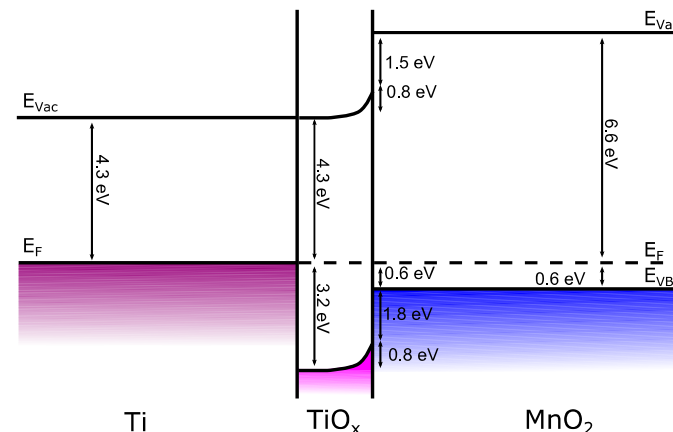
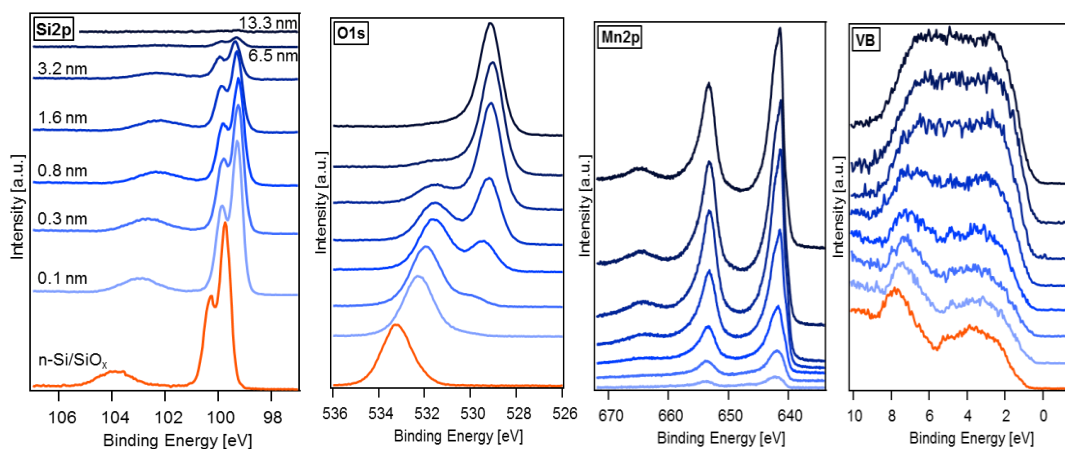

P. Connors et al. BK, WJ, unpublished results

Co-catalyst engineering: surface electronic structure and inner interfacial double layer potential drops



TECHNISCHE
UNIVERSITÄT
DARMSTADT

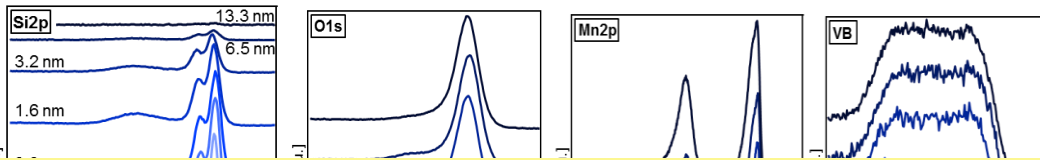

- Electrocatalysts needed with high electronic DOS close to E_F : study of surface electronic valence band structure
- Influence of interfacial layers formed at internal junctions: increase of overvoltage
- Internal and external potential losses lead to photovoltage losses due to interfacial dipolar potential drop: to be measured in surface science experiments and by changes of surface potentials

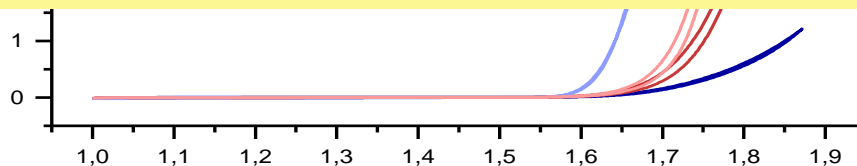
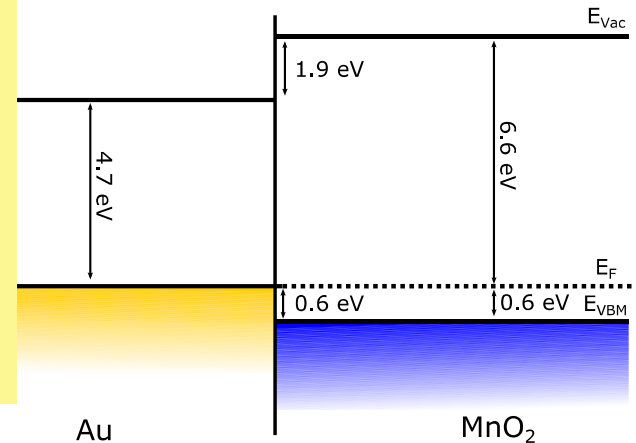
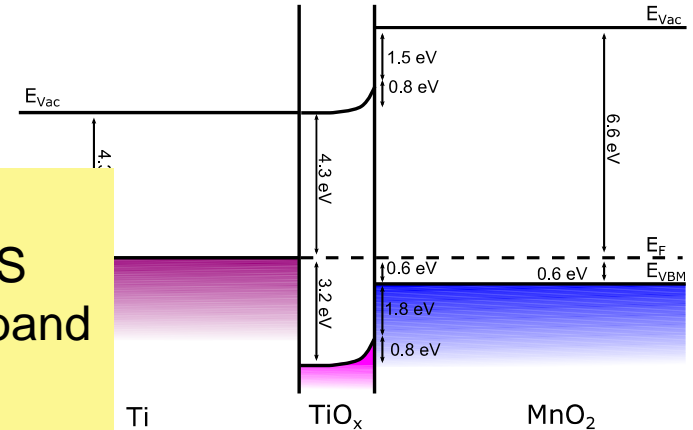

P. Connors et al. BK, WJ, unpublished results

Understanding interface engineering

Influence of different layers on contact potentials: -Surface layer

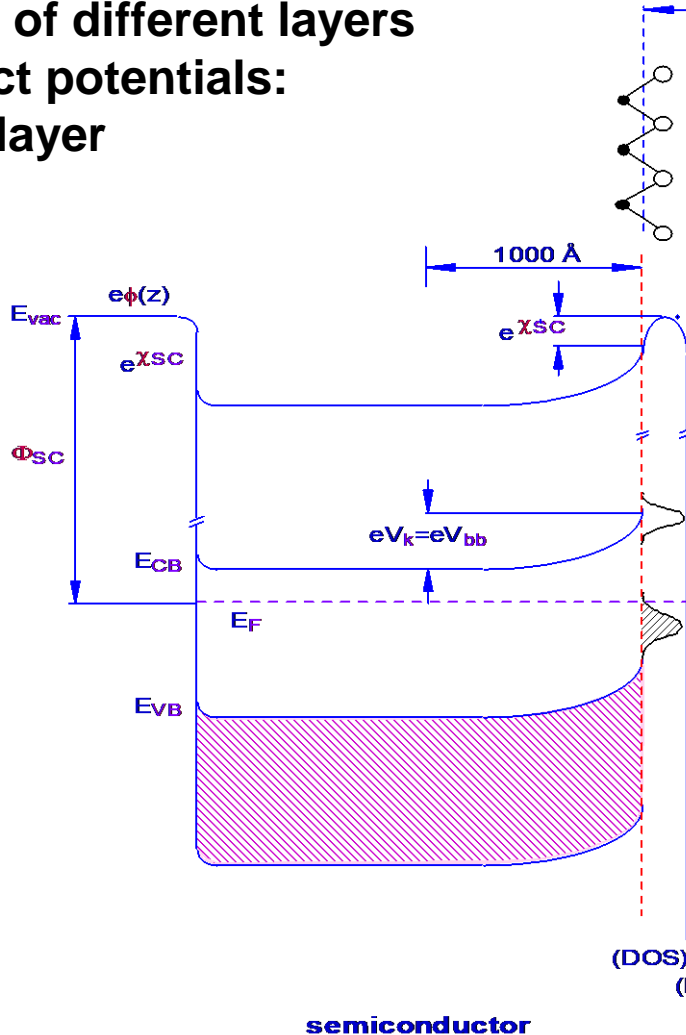

Electronic structure
and density of states:
-Surface layer

Stepwise formation of semiconductor/electrolyte interfaces

Influence of different layers
on contact potentials:

- Surface layer
- Adsorbate layer

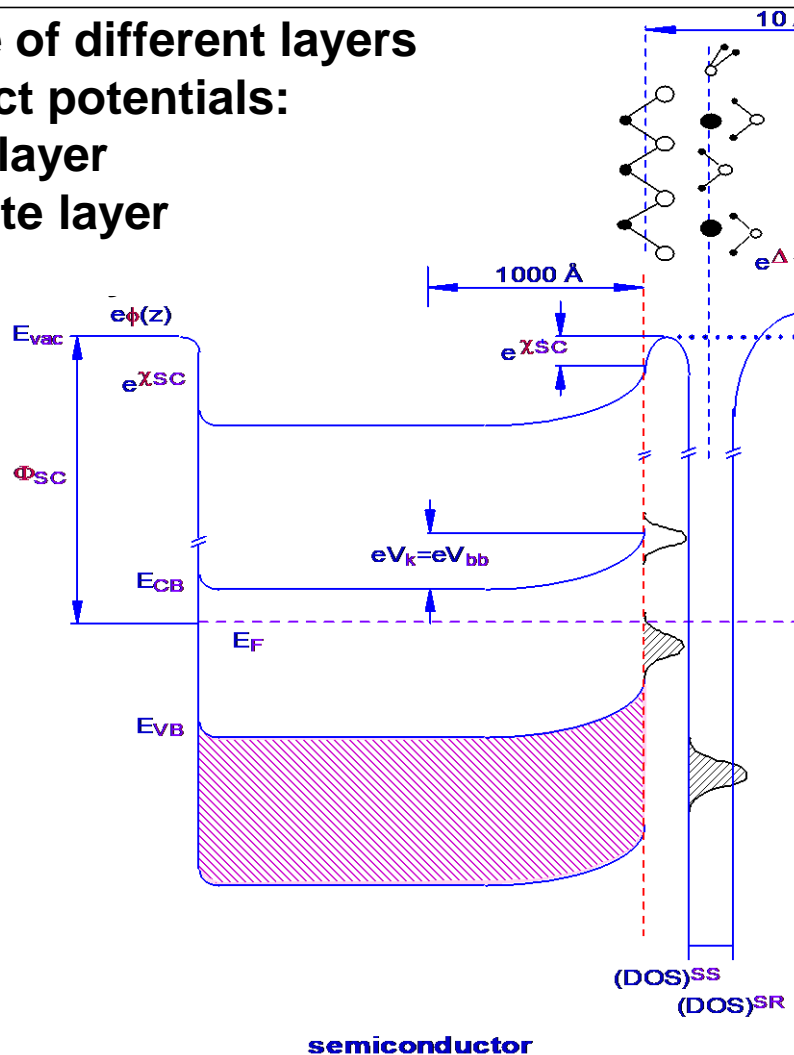

Electronic structure
and density of states:
-Surface layer
-Adsorbate layer

Stepwise formation of semiconductor/electrolyte interfaces

Influence of different layers
on contact potentials:

- Surface layer
- Adsorbate layer
- Electrolyte layer

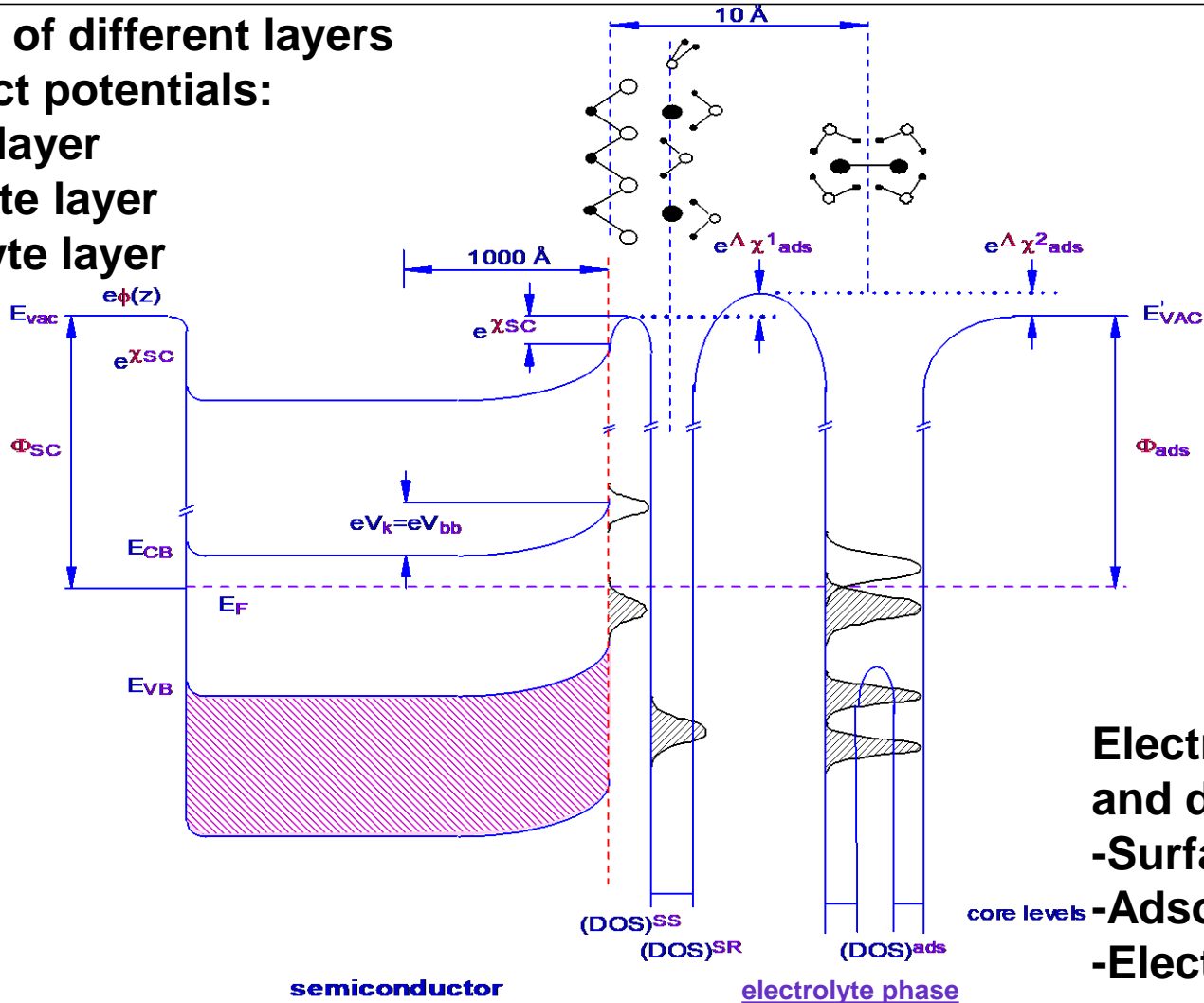

Electronic structure
and density of states:
-Surface layer
-Adsorbate layer
-Electrolyte layer

Stepwise formation of semiconductor/electrolyte interfaces

Influence of different layers
on contact potentials:

- Surface layer
- Adsorbate layer
- Electrolyte layer
- Passivation layer

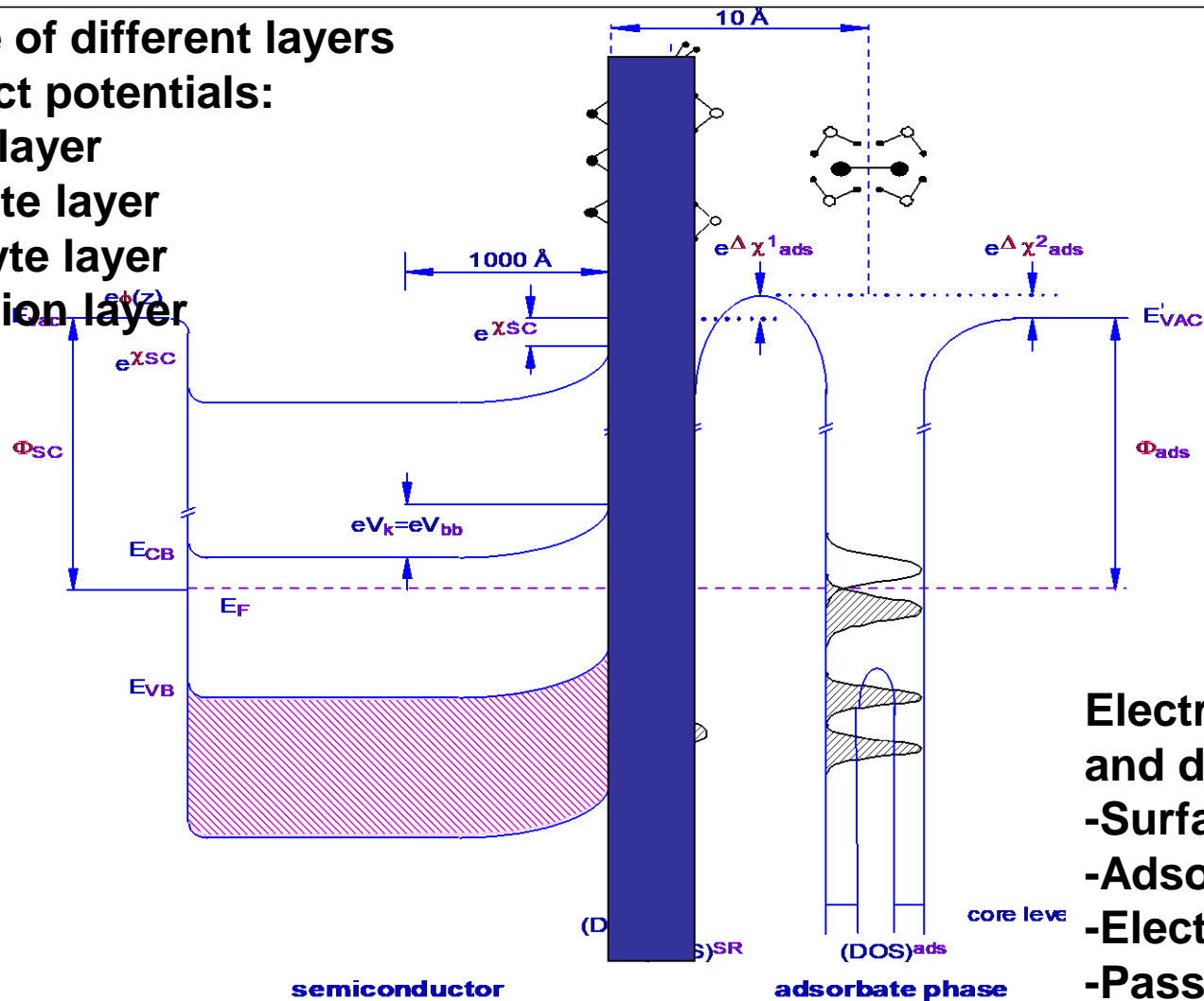

Electronic structure
and density of states:

- Surface layer
- Adsorbate layer
- Electrolyte layer
- Passivation layer

Stepwise formation of semiconductor/electrolyte interfaces

Influence of different layers
on contact potentials:

- Surface layer
- Adsorbate layer
- Electrolyte layer
- Passivation layer
- Metal Catalyst

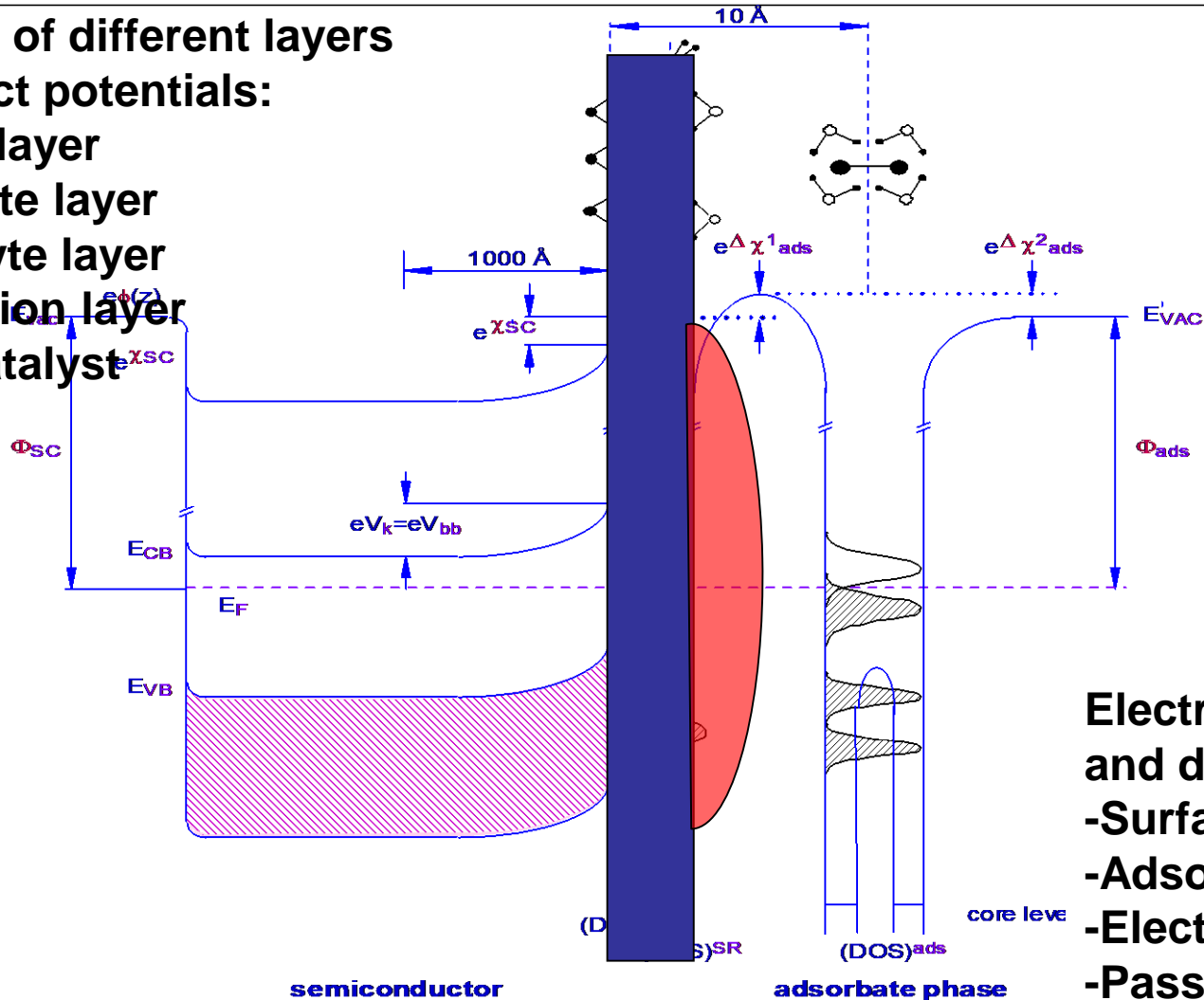

Electronic structure
and density of states:

- Surface layer
- Adsorbate layer
- Electrolyte layer
- Passivation layer
- Metal contact

Comparison PV-EL vs PEC

Photovoltaic-electrolyzer cell (PV-EL)

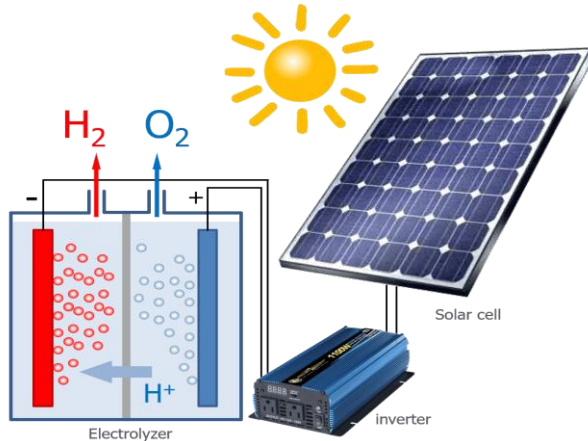

- ✗ Heat degrades PV performance
- ✗ Many components ⇒ high costs
- ✗ Noble metal catalysts

Photoelectrochemical cell (PEC)

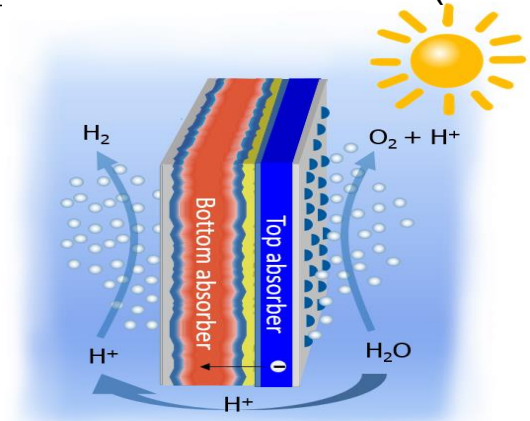

- ✓ Heat accelerates reactions
- ✓ Integration reduces costs
- ✓ Low J_{photo} → cheap catalysts

For adjusted coupling of PV and catalysts component PV-EC and PEC provide the same STH efficiencies and j - V dependencies, which needs

- alignment of electrochemical potentials of electrons and holes across interfaces
- no recombination via defect levels
- fast charge transfer/no ohmic losses across interfaces



- PEC H₂ may provide advantages compared to PV-EL combinations
- comparable basic research needs allow different technology decisions

L'Eridan - Chalet Giersch

... and you for your attention

the funding agencies DFG, BMBF, EC, industry
for their support

Thanks...

... the coworkers (2018*) for their input

* Since 2019 I am in an active retirement mode

